



BBO Pockels cell シリーズ

BBO Pockels cell with two BBO crystals



800nm

Crystal size: 3x3x20 mm
Clear aperture: diameter 2.5 mm
Quarter wave voltage at 800 nm: < 1.3 kV DC
Capacitance: < 6 pF
Optical transmission: > 98 % at 800 nm
Contrast ratio in crossed polarizers (ICR): > 1:500 (no voltage is applied)
Damage threshold of dielectric AR coatings: > 0.5 GW/cm², 1064 nm, 10 Hz, 10 ns
With ceramic apertures on both ends
Cell size: diameter 25.4 mm x 57.2 mm (L)

1030nm

Crystal size: 3x3x20 mm
Clear aperture: diameter 2.5 mm
Quarter wave voltage at 1030 nm: < 1.8 kV DC
Capacitance: < 6 pF
Optical transmission: > 98 % at 1030 nm
Contrast ratio in crossed polarizers (ICR): > 1:500 (no voltage is applied)
Damage threshold of dielectric AR coatings: > 0.5 GW/cm², 1064 nm, 10 Hz, 10 ns
With ceramic apertures on both ends
Cell size: diameter 25.4 mm x 57.2 mm (L)

1064nm

Crystal size: 3x3x20 mm
Clear aperture: diameter 2.5 mm
Quarter wave voltage at 1064 nm: < 1.8 kV DC
Capacitance: < 6 pF
Optical transmission: > 98 % at 1064 nm
Contrast ratio in crossed polarizers (ICR): > 1:500 (no voltage is applied)
Damage threshold of dielectric AR coatings: > 0.5 GW/cm², 1064 nm, 10 Hz, 10 ns
With ceramic apertures on both ends
Cell size: diameter 25.4 mm x 57.2 mm (L)

1064nm

Crystal size: 4x4x20 mm
Clear aperture: diameter 3.5 mm
Quarter wave voltage at 1064 nm: < 2.3 kV DC
Capacitance: 6 pF
Optical transmission: > 98 % at 1064 nm
Contrast ratio in crossed polarizers (ICR): > 1:500 (no voltage is applied)
Damage threshold of AR coatings: > 0.5 GW/cm² (5 J/cm²), 1064 nm, 10 Hz, 10 ns
With ceramic apertures and protective windows on both ends
Cell size: diameter 25.4 mm x 57.2 mm (L)



詳しい問い合わせ：有限会社アミスター
〒146-0085 東京都大田区久が原1-5-7-302
TEL:03-6410-4277 FAX:03-6410-4278
E-mail:info@amistar.jp

MECHANICAL DRAWING

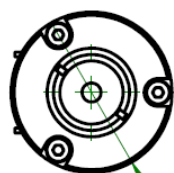

$\phi 25,40$

Connection terminals

17,60

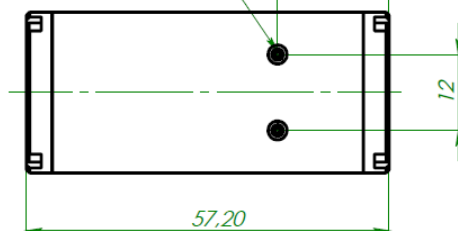

57,20

12

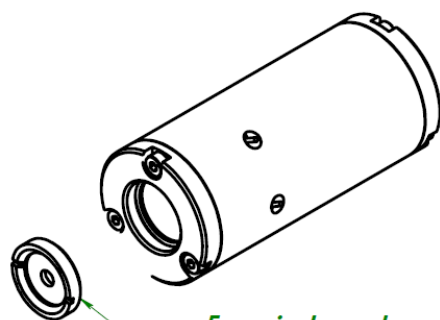

*For window cleaning
ceramic aperture can be easily
removed*

高繰り返し率のポケセルドライバー

- 3.1kVまでのHVパルス振幅
- 最大6MHzの繰り返し率
- <1nsまでのHVパルス持続時間
- パルス再生技術を使用したHVパルス持続時間の延長

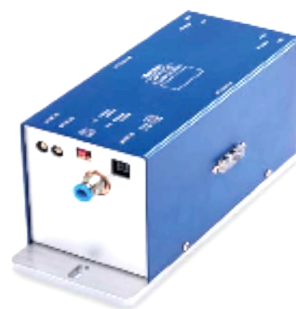

CATALOGUE NUMBER OF DRIVER	2DP-1000-2.4-AI	2DP-2000-1.6-AI	DPB3-2500-3.1-AI	DPB3-3000-2.6-AI	2DPB3-4000-1.7-AI	2DPB3-6000-1.3-AI
Maximal HV operating voltage	2.4 kV	1.6 kV	3.1 kV	2.6 kV	1.7 kV	1.3 kV
Maximal HV repetition rate	1000 kHz	2000 kHz	2500 kHz	3000 kHz	4000 kHz	6000 kHz
Pulse duration	0 – 5000 ns		100 – 5000 ns		0 – 5000 ns	
HV pulse rise time, typical	< 6.5 ns	< 6 ns	< 9.5 ns	< 8.5 ns	< 10.5 ns	< 8.5 ns
HV fall rise time, typical	< 6.5 ns	< 6 ns	< 9.5 ns	< 8.5 ns	< 10.5 ns	< 8.5 ns
Output polarity	Positive		Bipolar		Positive	
HV power consumption	< 180 W	< 130 W	< 360 W	< 325 W	< 360 W	< 330 W
24 V power consumption	< 14 W	< 18 W	< 10 W	< 10 W	< 6 W	< 10 W
Recommended HV power supply model	HV-200 or HVS100-2x120		HV-2x200		HV-400	
Dimensions	See Fig. 17			See Fig. 18		
Cooling	Water					

Driver needs to be mounted on heatsink unless it is cooled by water. Driver's base plate temperature needs to be lower than 35 °C in all regimes of operation. Power consumption for 6 pF load. Voltage or repetition rate derating is necessary if capacitance of your Pockels cell is higher. Contact vendor for details.

MECHANICAL DRAWING

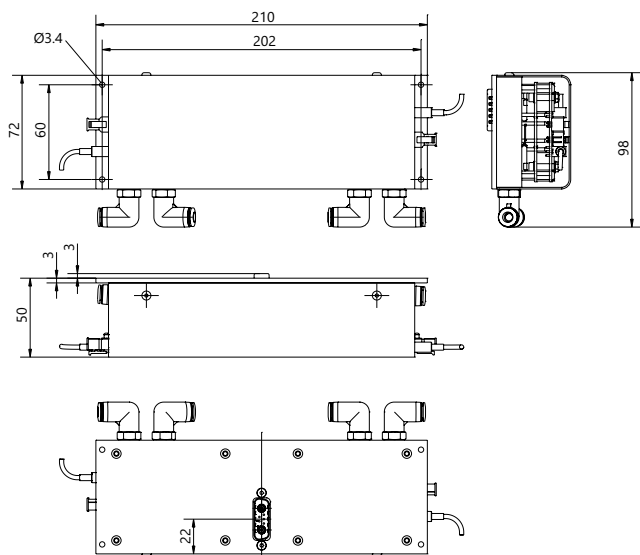

Fig. 17. Outline drawing of encased version
2DP series Pockels cell drivers

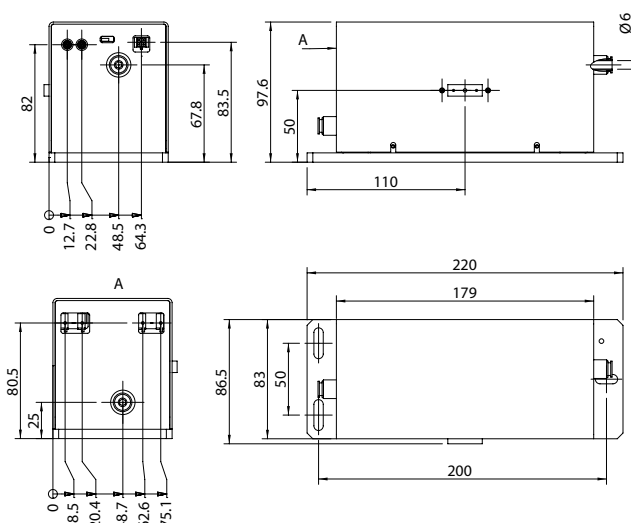

Fig. 18. Outline drawing of encased version
2DPB3/DPB3 series Pockels cell driver